

Key Issues in Multilateral Technology

Drilling, completing and later reentering wells with multiple branches to improve production while saving time and money are becoming commonplace, but complications remain, as do the risks and chances of failure. Existing techniques have been applied and fresh approaches are being developed to overcome technical hurdles, establishing new standards and a specialized vocabulary for these well types and applications.

Steve Bosworth

Union Pacific Resources
Fort Worth, Texas, USA

Hussein Saad El-Sayed

Dubai, United Arab Emirates

Gamal Ismail

Zakum Field Development Company
Abu Dhabi, United Arab Emirates

Hervé Ohmer

Mark Stracke

Chris West

Sugar Land, Texas, USA

Albertus Retnanto

Jakarta, Indonesia

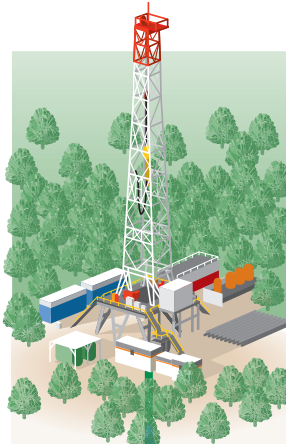

In 1953, a unique oil well called simply 66/45 was drilled with turbodrills in the Bashkiria field near Bashkortostan, Russia. This well ultimately had nine lateral branches from a main borehole that increased exposure to the pay zone by 5.5 times and production by 17-fold, yet the cost was only 1.5 times that of a conventional well.¹ It was the world's first truly multilateral well, although rudimentary attempts at multilaterals had been made since the 1930s. Under the auspices of the Soviet Oil Industry Ministry, another 110 such wells were drilled in Russian oil fields over the next 27 years (see "The Father of Multilateral Technology," page 16). Not until ARCO drilled the K-142 dual-lateral well in New Mexico's Empire field in 1980, did another operator attempt such a feat, for multilaterals were simply too difficult and too risky, requiring substantial investment of both time and technology.

A multilateral well is a single well with one or more wellbore branches radiating from the main borehole. It may be an exploration well, an infill development well or a reentry into an existing well. It may be as simple as a vertical wellbore with one sidetrack or as complex as a horizontal, extended-reach well with multiple lateral and sublateral branches. General multilateral configurations include multibranching wells, forked wells, wells with several laterals branching from one horizontal main wellbore, wells with several laterals branching from one vertical main wellbore, wells with stacked laterals, and wells with dual-opposing laterals (next page, top). These wells generally represent two basic types: vertically staggered laterals and horizontally spread laterals in fan, spine-and-rib or dual-opposing T shapes.

For help in preparation of this article, thanks to Lennis Cook, Anadrill, Sugar Land, Texas, USA; Chip Corbett, GeoQuest, Houston, Texas; Vladimir Doroshenko, Schlumberger Wireline & Testing, Moscow, Russia; Doug Durst, Weatherford, Houston, Texas; Alexander Mikhailovich Grigoryan, Los Angeles, California, USA; David Hill, Anadrill, Shekou, Shenzhen, China; David Malone, Camco, Houston, Texas; Pat McKinley, Anadrill, Midland, Texas; Eric Neme, Schlumberger Oilfield Services, Lagos, Nigeria; and Claire Vishik, Austin Product Center, Austin, Texas.

INFORM (Integrated Forward Modeling), PowerPak, RapidAccess, RapidConnect, Slim 1, USI (UltraSonic Imager) and VIPER are marks of Schlumberger.

1. Horizontal Well Technology Unit, Heriot-Watt University and The Petroleum Science and Technology Institute, Multi-Lateral Well Technology Technical Study (1995): 6-9.
2. Horizontal Well Technology Unit, reference 1: 6-14.

Vertically staggered wells usually target several different producing horizons to increase production rates and improve recovery from multiple zones by commingling production. Wells in the Austin Chalk play in Texas (USA) are typically of this type (below right). Their production is a function of the number of natural fractures that the wellbore encounters. A horizontal well has a better chance of intersecting more fractures than a vertical well, but there is a limit to how far horizontal wells can be drilled. By drilling other laterals from the same wellbore, twice the number of fractures can often be exposed at a much lower cost than drilling long horizontal sections or another well.

Horizontal fan wells and their related branches usually target the same reservoir interval. The goal of this type of well is to increase production rates, improve hydrocarbon recovery and maximize production from that zone. Multiple thin formation layers can be drained by varying the inclination and vertical depth of each drainhole. In a naturally fractured rock with an unknown or variable fracture orientation, a fan configuration can improve the odds of encountering fractures and completing an economic well. If the fracture orientation is known, however, a dual-opposing T well can double the length of lateral wellbore exposure within the zone. In nonfractured, matrix-permeability reservoirs, the spine-and-rib design reduces the tendency to cone water. Lateral branches are sometimes curved around existing wells to keep horizontal wellbores from interfering with a vertical well's production.

A successful multilateral well that replaces several vertical wellbores can reduce overall drilling and completion costs, increase production and provide more efficient drainage of a reservoir. Furthermore, multilaterals can make reservoir management more efficient and help increase recoverable reserves. But why has it taken so long for multilateral technology to catch on?

Between 1980 and 1995, only 45 multilateral well completions were reported; since 1995, hundreds of multilateral wells have been completed and many more are planned over the next few years.² This increased number of multilateral wells is related to a rapid sequence of advances in the methods for drilling multilateral wells—directional and horizontal drilling techniques, advanced drilling equipment and coiled tubing drilling. However, the levels of well complexity have remained low due to a lack of comparable advances in multilateral completion equipment and designs. As a consequence, the primary risks involved in multilateral wells have been in lateral junction construction and completion rather than

(continued on page 18)

Multilateral Well Configurations

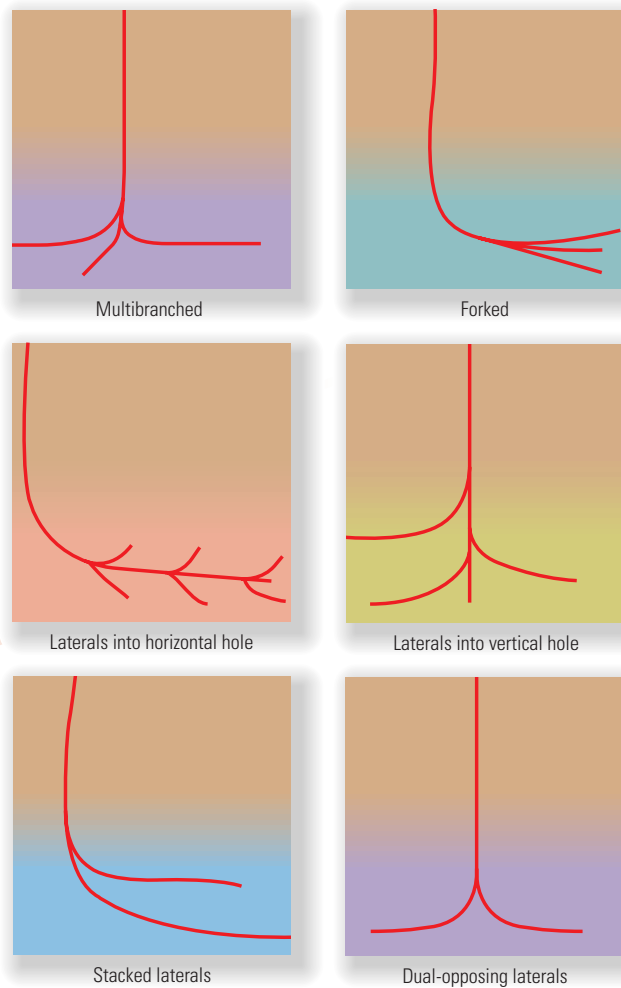

^ Common forms of multilateral wells in use today. Wellbore design and configuration are dictated by specific formation and reservoir drainage requirements.

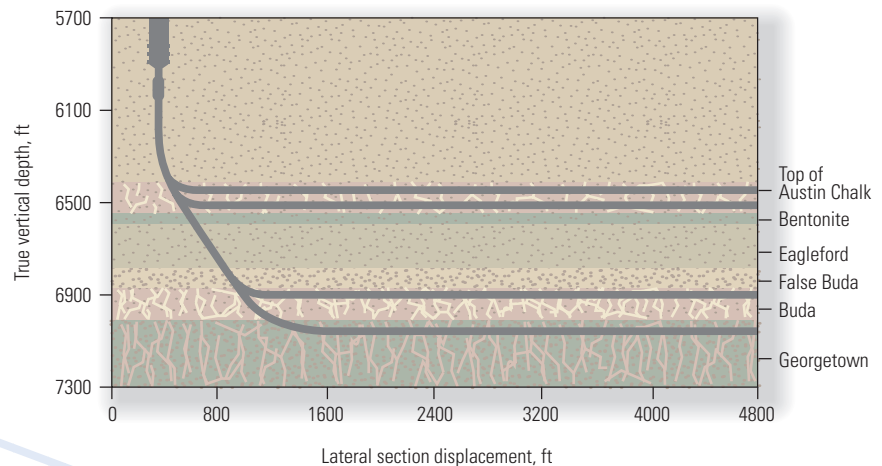

^ Typical Austin Chalk well in south Texas, USA. Stacked drainholes target multiple zones to increase production rates and improve recovery by commingling production. Horizontal wells have a better chance of intersecting natural fractures than vertical wells; production is a function of the number of fractures that the wellbore encounters.

The Father of Multilateral Technology

As with many advances in petroleum technology, the first multilateral well was accomplished by a Soviet drilling engineer. Alexander Mikhailovich Grigoryan was born during 1914 in Baku, the capital of today's Republic of Azerbaijan, then a principal center of oil production. After graduation from high school, he worked as a driller's assistant, became an apprentice and ultimately graduated as a petroleum engineer in 1939 from Azerbaijan Industrial Institute ([right](#)).

During most of the Soviet era, the official policy was to produce as much oil as possible, since it was a strategic commodity and one of the few exports that could be exchanged for grain and other consumer goods. High quotas were imposed on drillers to bore as many holes as they could. The prevailing attitude was that the more holes drilled, the greater the likelihood of successfully tapping a reservoir and thereby achieving greater production.

Grigoryan was an innovator and inventor. Upon graduation, he began working as an oil-field driller and soon was attached to the Ministry of Oil. Believing that he could produce more oil by following a known oil sand than by merely penetrating it with a number of boreholes, he drilled one of the world's first directional wells—Baku 1385—in 1941, nearly 20 years before anyone else attempted such a feat. Without a whipstock or a rotating drillstring, he used a downhole hydraulic motor to penetrate oil-bearing rock and significantly expand reservoir exposure and production. It was the first time that a turbodrill was used for both vertical and horizontal sections of a borehole.¹

Grigoryan's pioneering work in horizontal drilling technology led to scores of other successful horizontal wells across the USSR and his elevation to department head at the All-Union Scientific-Research Institute for Drilling Technology (VNIIBT). He was not, however, satisfied with these accomplishments. He developed a new borehole sidetrack kickoff technique and a device for stabilizing and

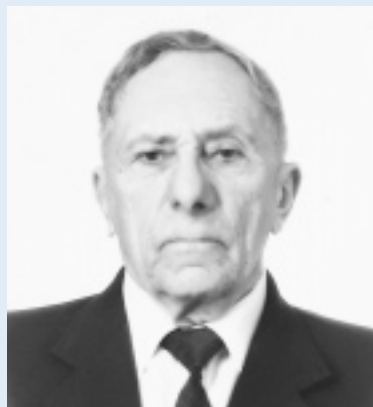

^ Alexander Mikhailovich Grigoryan. Now 84 years of age, Grigoryan immigrated to the United States in the 1980s and became an American citizen. He kindly granted *Oilfield Review* an interview and made documents about his technique available.

controlling curvature without deflectors. But all of these innovations were in preparation for his major contribution to drilling technology.

Inspired by the theoretical work of American scientist L. Yuren, who maintained that increased production could be achieved by increasing borehole diameter in the productive zone, Grigoryan took the theory a step further and proposed branching the borehole in the productive zone to increase surface exposure, "just as a tree's roots extend its exposure to the soil." In 1949, he took his ideas to noted Russian scientist K. Tsarevich, who confirmed that branching a well in a productive zone with uniform rock permeability should yield an increase in oil production in proportion to the number of branches.

Grigoryan put this new theory into practice in the Bashkiria field complex in what is today Bashkortostan, Russia ([right](#)). There, in 1953, he used downhole turbodrills without rotating drillstrings to drill Well 66/45, the first multilateral well. Bashkiria field complex lies in southern Bashkortostan ([next page, left](#)). Late

Carboniferous carbonate reefs built by rugose corals trap vast oil reserves ([next page, right](#)). The fields had been in production since before 1930, and most wells produced low volumes at the time Grigoryan first attempted a multilateral well.²

Grigoryan chose to drill Well 66/45 in Bashkiria's Ishimbainefti field, which evidenced an interval of Artinskian carbonate rocks with good reservoir properties and wide areal distribution. His target was the Akavassky horizon, an interval that ranged from 10 to 60 m [33 to 197 ft] thick.

Grigoryan drilled the main bore to a total depth of 575 meters [1886 ft], just above the pay zone. From that point, he drilled nine branches from the open borehole without cement bridges or whipstocks; the window configuration enabled insertion of tools on drillpipe into the

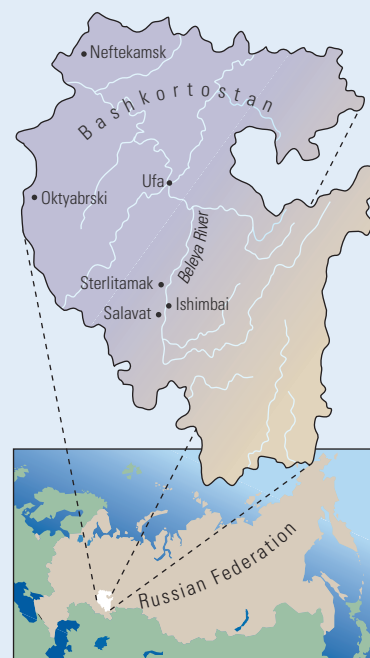

^ Map of Bashkortostan inset in a map of the Russian Federation. The first multilateral wells were drilled in the Ishimbai region in the south-central region of the republic.

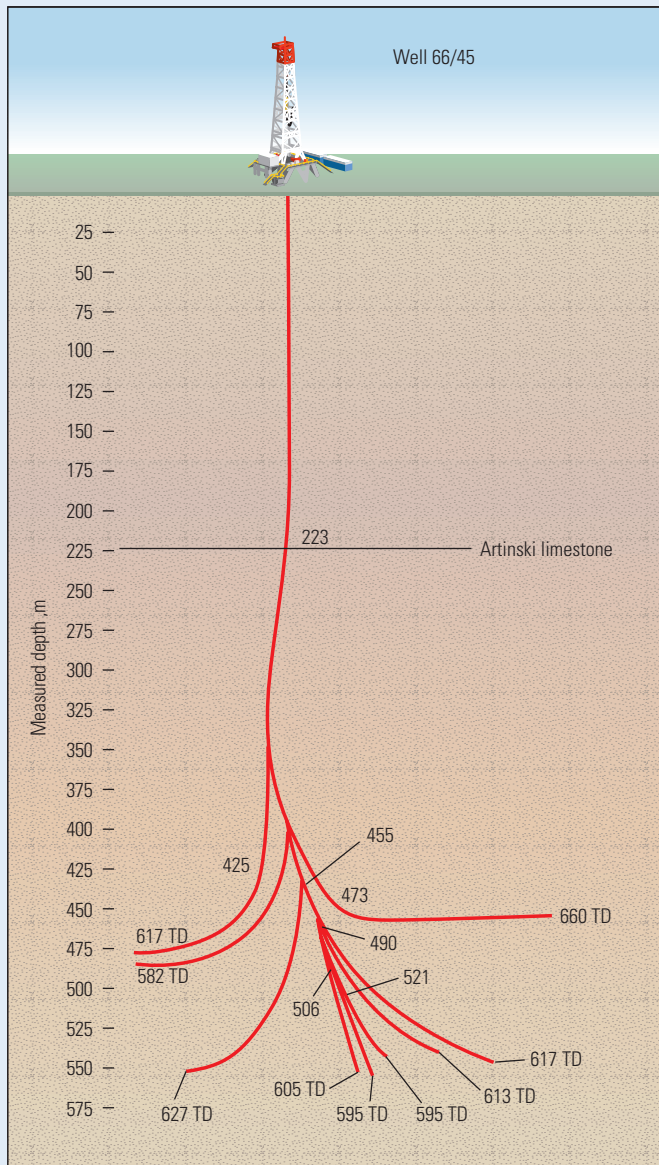

^ An early multilateral well. Drilled in Bashkirea, now Bashkortostan, one of Russia's most prolific regions, the first multilateral well had nine lateral branches that tapped the Ishimbainefti field reservoir.

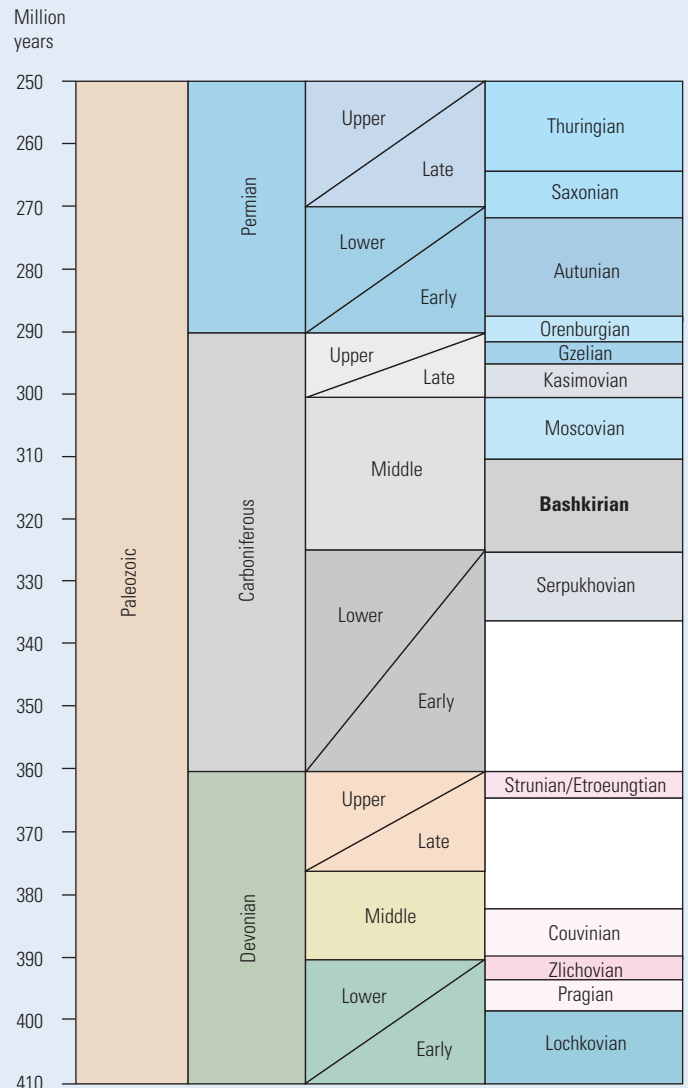

^ Bashkirea stratigraphic column. The first multilateral well target was within the Akavassky horizon, in the center of the lower Bashkiran sequence, middle Carboniferous era. [Adapted from Haq BU and Van Eysinga FWB: Geological Time Table, 4th ed. Amsterdam, The Netherlands: Elsevier Science BV, 1994.]

sidetracks without instrumentation. He drilled by touch alone, "slanting away from the vertical bore like roots of a tree, each branch extending for 80 to 300 meters [262 to 984 ft] in different directions into the producing horizon."³ Grigoryan allowed the drill bit to follow the pay zone into the most productive zones, the branches curving automatically to the planned trajectory. Drilling speed and penetration rate depended entirely on the hardness of the rock and downhole motor capabilities.

When completed, Well 66/45 had nine producing laterals with a maximum horizontal reach from kickoff point of 136 meters [447 ft] and a total drainage of 322 meters [1056 ft].

Compared with other wells in the same field, 66/45 penetrated 5.5 times the pay thickness. Its drilling cost was 1.5 times more expensive, but it produced 17 times more oil at 755 B/D [120 m³/d] versus the typical 44 B/D [7 m³/d].⁴

Under the auspices of the Soviet Oil Industry Ministry, another 110 multilateral wells were drilled in Russian oil fields over the next 27 years, with Grigoryan drilling 30 of them himself. About 50 of these first multilaterals were exploratory, the remainder were for delineation of reefs and channel structures.

1. Gaddy D: "Pioneering Work, Economic Factors Provide Insights into Russian Drilling Technology," *Oil & Gas Journal* 96, no. 27 (July 6, 1998): 67-69.
2. Boisseau T, Chuvashov B, Ivanova R, Maslo A, Masse P, Proust J-N, Vachard D and Vennin E: "Etude Sedimentologique et Biostratigraphique du Stratotype du Bashkiran (Oural du Sud, Russie)," *Bulletin, Centres Recherche Exploration-Production, Elf Aquitaine* 20, no. 2 (December 1996): 341-365.
3. Bakke D: "Russia Gears Up Offshore Activity for Biggest Production Gains in Its History," *Offshore* 35, no. 5 (May 1975): 303-306.
4. Horizontal Well Technology Unit, Heriot-Watt University and The Petroleum Science and Technology Institute, Multi-Lateral Well Technology Technical Study, 1995: 6-9.

drilling. Of the hundreds of multilateral wells drilled, most have been simple openhole completions in hard rock; many have been reentries to salvage wells or boost output from old fields, but an increasing number represents new, development wells seeking to maximize drainage of known reservoirs.

Regardless of the level of complexity, multilateral wells today are drilled with state-of-the-art directional drilling technology. Even so, the drilling of multilateral wells involves certain risks ranging from borehole instability, stuck pipe and problems with overpressured zones to casing, cementing and branching problems. And there can be a high risk of drilling or completion formation damage and difficulties locating and staying in the productive zone while drilling the laterals.

Multilateral technology may be at about the same level of development that horizontal and directional drilling were 10 years ago. Horizontal and reentry multilateral drilling has increased 50% over the past five years and is expected to grow another 15% a year through 2000.³ This rapid growth is attributed to operators realizing that the advantages of multilateral systems increasingly outweigh the disadvantages.

For years, because there were so few reliable and sophisticated examples of successful multilateral applications, few such wells were drilled because operators lacked benchmarks by which to determine whether prospects were suitable candidates for multilateral development (right). There were concerns about higher initial costs and the risk of possible interference of laterals with each other, crossflow and difficulties with production allocations. An increased sensitivity to and concern about reservoir heterogeneities like vertical permeability deterred multilateral development. The prospect of complicated drilling, completion and production technologies, complicated and expensive stimulation, slow and less effective cleanup, and cumbersome well-bore management during production also made operators cautious.

As more multilaterals were drilled successfully, however, even the simplest wells demonstrated the potential of this emerging technology. The main benefits of these successful wells have been increased production, increased reserves and an overall reduction in reservoir development costs.

Production from known reserves has traditionally been expanded by drilling additional wells to increase drainage and sweep efficiency. As a consequence, both capital expenditures and operating costs have also increased with every

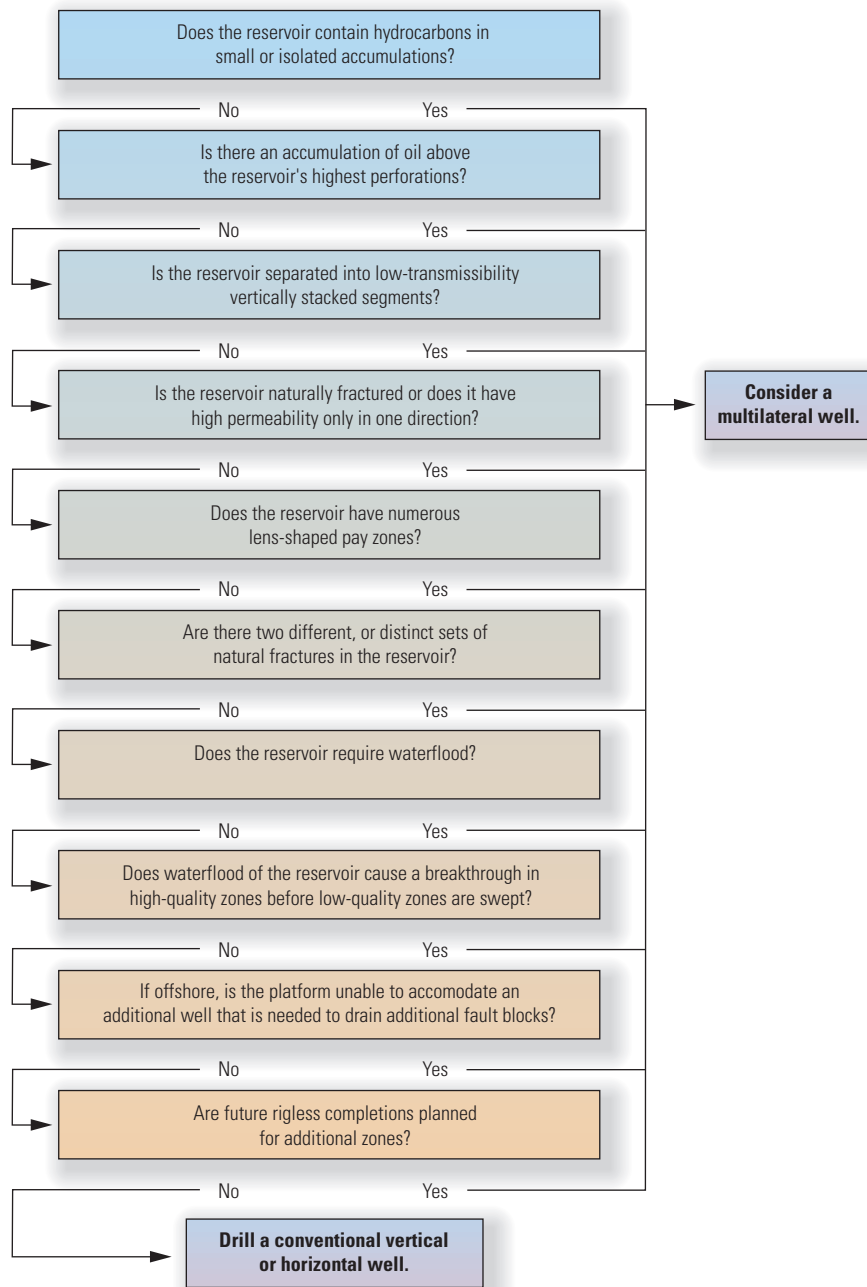

^ Determining if multilateral technology is applicable.

new well. To counteract these cost increases, multilateral technology is now being employed to increase borehole contact with the reservoir, improve operating efficiency and reduce well costs. These goals are achieved primarily by drilling the main trunk and overburden from surface to the reservoir only once and by reducing surface equipment to a single installation at a significant cost-savings. Furthermore, this can be achieved in both offshore platform and subsea situations where a limited number of slots is available and in onshore locations where surface installations are expensive or where the lease has an irregular configuration.

Multiple lateral penetrations in the same reservoir or in independent reservoirs not only produce significant cost-savings, but increase production rates appreciably (next page). Such penetrations are commonly used to increase the effective drainage and depletion of a reservoir, particularly when reservoirs have restricted hydrocarbon mobility due to low permeability, low porosity or other characteristics that limit production flow. When independent reservoirs are targeted, production can either be commingled into a single production tubing string or produced separately in multiple production tubing strings. Multilateral wells are also an economical

3. Longbottom J and Herrera I: "Multilateral Wells Can Multiply Reserve Potential," *American Oil & Gas Reporter* 40, no. 9 (September 1997): 53-58.

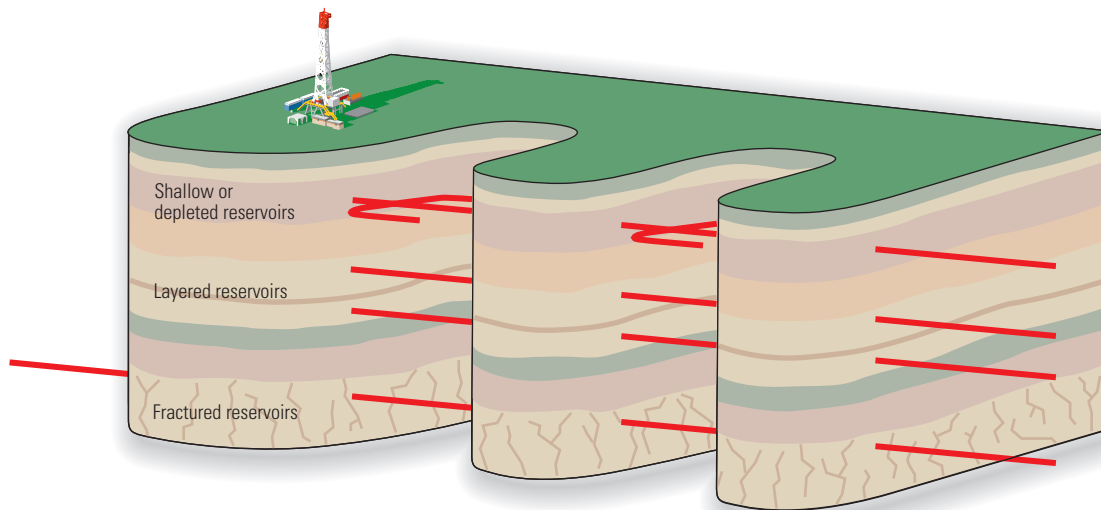

^ Enhancing productivity with multilateral well configurations. In shallow or depleted reservoirs, branched horizontal wellbores are often most efficient, whereas in layered reservoirs, vertically stacked drainholes are usually best. In fractured reservoirs, dual-opposing laterals may provide maximum reservoir exposure, particularly when fracture orientation is known.

way of rapidly depleting a reservoir, effectively accelerating production, shortening the field life cycle and reducing operating costs.

Multilateral wells are often able to overcome the shortcomings of both horizontal and conventional wells, particularly if there are geological factors like thinly layered formations or a significantly fractured system, and in specific enhanced oil recovery scenarios such as steam-assisted gravity drainage. In addition, the application of multilateral technology can result in decreased water and gas coning.

Because of the capability to more thoroughly drain reservoirs vertically and horizontally, recoverable reserves per well and per field are increased considerably while both capital and operating costs per well and per field are minimized. In fact, the cost of achieving the same degree of drainage with conventional wells would be prohibitive in most cases, especially situations like deepwater subsea developments. Multilateral wells allow costs to be amortized over several reservoir penetrations and in some cases have eliminated the need for infill drilling. In heterogeneous reservoirs with layers, compartments or randomly oriented natural fractures, more pockets of oil and gas can be exploited and an increased number of fractures can be intersected by drilling multilateral wells.

In anisotropic formations with unknown directions of preferred permeability, drilling multibranch wells can reduce economic risk. Lateral branches can balance the nonuniform productivity or injectivity of different layers. Multilateral wells provide extensive information about the reservoir and can be useful for exploration and formation evaluation in addition to their capability to efficiently and economically drain reservoirs.

TAML Classification

Until 1997, there was considerable confusion regarding multilateral technology. Few terms that described the technology were universally agreed upon, and a classification of multilateral wells by difficulty and risk was lacking. As a consequence, under the leadership of Eric Diggins of Shell UK Exploration and Production, a forum called "Technology Advancement—Multi Laterals (TAML)" was held in Aberdeen, Scotland, in the Spring of 1997. Its goal was to provide a more unified direction for multilateral technology development. Experts in multilateral technology from leading oil companies shared experiences and agreed to a classification system that ranks multilateral wells by complexity and functionality. Today, multilateral wells are referred to by level of complexity from Level 1 through 6S, and described with a code to represent type and functionality (see, "Classifying Multilateral Wells," page 20).

The three characteristics used to evaluate multilateral technology are connectivity, isolation and accessibility. Of these, the form of connectivity or junction between the main trunk and lateral wellbore branches is not only the most distinguishing feature, but also the riskiest and most difficult to achieve. For this reason, about 95% of multilateral wells drilled worldwide have been Level 1 or 2. Some 85% of 1998 multilaterals have been Levels 1 to 4, with 50% of those Levels 1 and 2. But the race is on; virtually all major operators and drilling service companies are developing multilateral connectivity, isolation and accessibility capabilities. In addition, new junction systems are emerging to facilitate increasingly higher levels of difficulty.

Level 1 is essentially a simple openhole sidetracking technique, much like the first multilaterals drilled in Russia. The main trunk and lateral branches are always openhole with unsupported junctions. Lateral access and production control are limited.

In Level 2 wells, the main bore is cased, but the lateral junction remains openhole, or possibly with a "drop-off" liner—casing placed in lateral sections without mechanical connection or cementing—to provide full-opening main wellbore access and improve the potential for reentry into the lateral.

Anadrill performs Level 1 and 2 multilateral connections throughout North America and the Middle East (see, "Multilaterals in the Middle East," page 24). Drilling is usually carried out with either short-radius or medium-long radius drilling assemblies. The Anadrill RapidAccess system and third-party casing exiting services like those of Smith International are used to provide support. Milling can also be carried out in existing wells using conventional retrievable whipstock or cement plug techniques. Other providers can supply similar systems or junctions with windows precut.

Level 2 wells commonly require a window, or hole, to be cut in the casing with a milling assembly. Generally, this level of multilateral consists of whipstock sidetracks from existing casing

Classifying Multilateral Wells

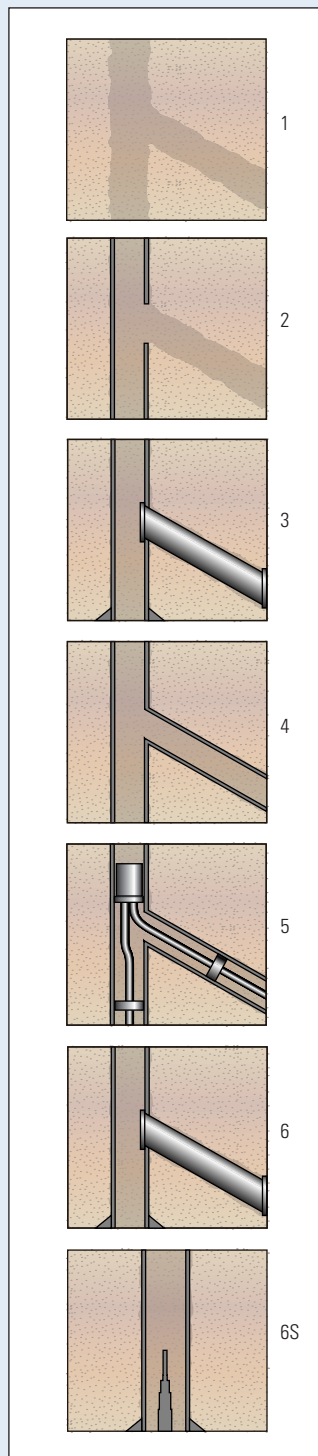

< **Multilateral well complexity ranking (Level 1 to 6S).** This general classification is based on junction complexity. Level 1 is an openhole sidetrack or unsupported junction. Level 2 has a cased and cemented main bore, or trunk, with openhole lateral. Level 3 is a cased and cemented main bore with lateral cased, but not cemented. Level 4 has both main bore and lateral cased and cemented at the junction. Level 5 pressure integrity is achieved at the junction with completion equipment. For Level 6, junction pressure integrity is achieved with casing and without the assistance of or dependence on completion equipment. In the subcategory Level 6S, a downhole splitter, basically a subsurface dual-casing wellhead, divides a large main bore into two equal-size laterals.

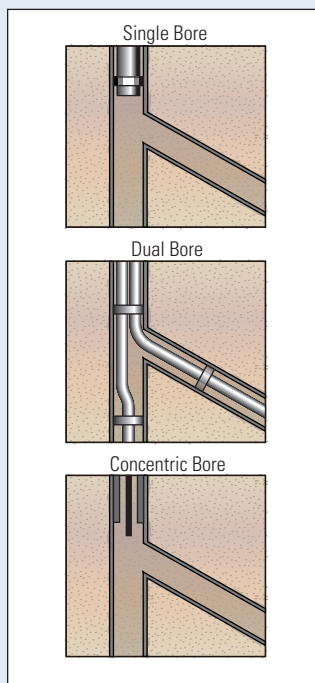

^ **Multilateral well descriptions.** In addition to criteria such as the number of junctions and well type—producer with or without artificial lift, injector or multipurpose—the completion type, whether single, dual or concentric, has a major impact on the type of equipment that is needed at the junction.

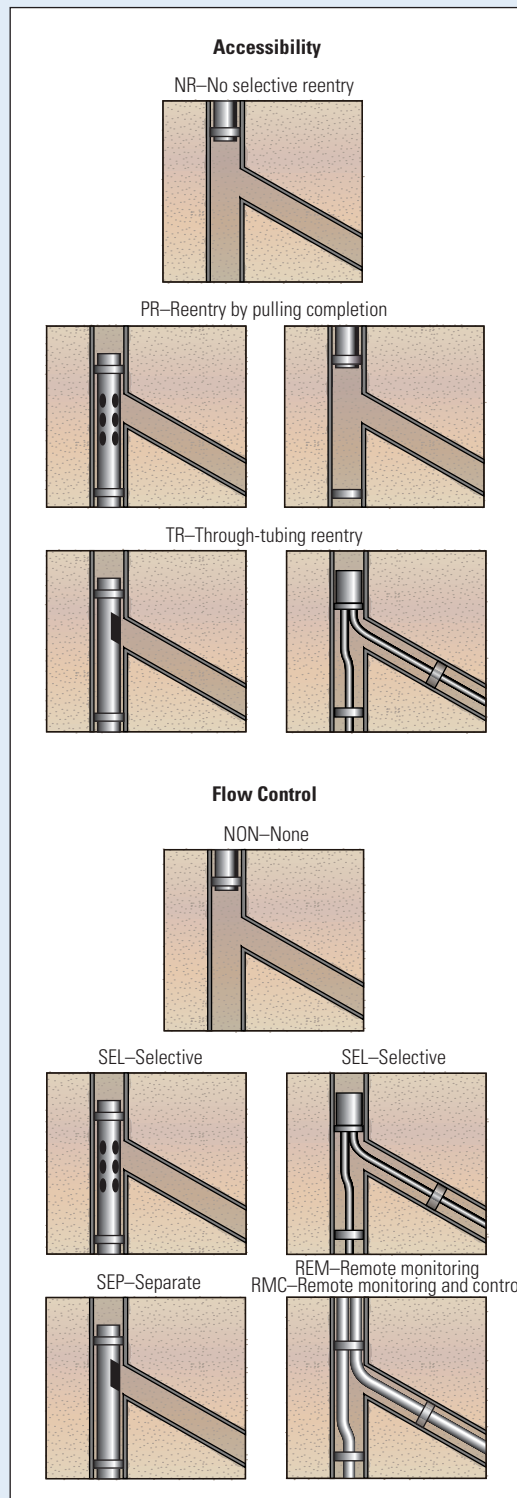

^ **Junction types.** The categories of accessibility are no selective reentry, reentry by pulling completion and through-tubing reentry (top). Flow control (bottom) is the degree to which fluid flow across a junction can be adjusted—no control, selective or separate control, and remote monitoring or remote monitoring and control.

(right). Premilled window casing subs are also used frequently to avoid the higher risk task of milling. Although retrievable whipstocks are employed to drill laterals, their removal along with the packer assembly from the main wellbore makes locating laterals and reentry access almost impossible. Accurate positioning of subsequent guide assemblies and azimuthal orientation are also difficult if not impossible. For this reason, the Anadrill Level 2 RapidAccess multilateral completion system was enhanced by adding a mechanical connection with a fullbore casing profile nipple for positioning and orienting whipstocks or other assemblies to provide selective drainhole access.

The Level 2 RapidAccess construction was engineered with robust simplicity to be transparent to the drilling operation, while retaining options for higher level multilateral completions. RapidAccess couplings do not require orientation or special procedures during installation and are cemented using conventional equipment and procedures. These couplings are full opening, permanent reference points from which multiple branches can be constructed and reentered from the main wellbore. Since orientation prior to cementing is not required, casing movement during primary cementing helps ensure a successful cement bond. Multiple RapidAccess couplings can be installed in casing strings to allow numerous reservoir penetrations for optimum field development. Depth and orientation of each coupling can be determined by measurements-while-drilling (MWD) survey after cementing and by wireline or coiled-tubing conveyed USI UltraSonic Imager surveys (right).

Level 3 multilateral technology offers both connectivity and access. The main trunk and laterals are cased; the main bore is cemented, but laterals are not. Until recently, only premilled windows were used at this level if access into each lateral needed to be maintained. Lateral liners are anchored to the main bore by a liner hanger or other latching system, but cementing is not required. There is no hydraulic integrity or pressure seal at the lateral liner and main casing junction, but there is main bore and lateral reentry access.

The Level 3 RapidConnect system will provide mechanical connectivity to both the lateral and main wellbore and high-strength junctions for unstable formations. This enhancement is critical when sands or shales become unstable over the productive life of a well. Completion options that may be required by the reservoir depletion plan allow upper laterals to be isolated at the junction while producing from lower laterals. Selective access to laterals is made possible by placing an oriented diverter at the junction.

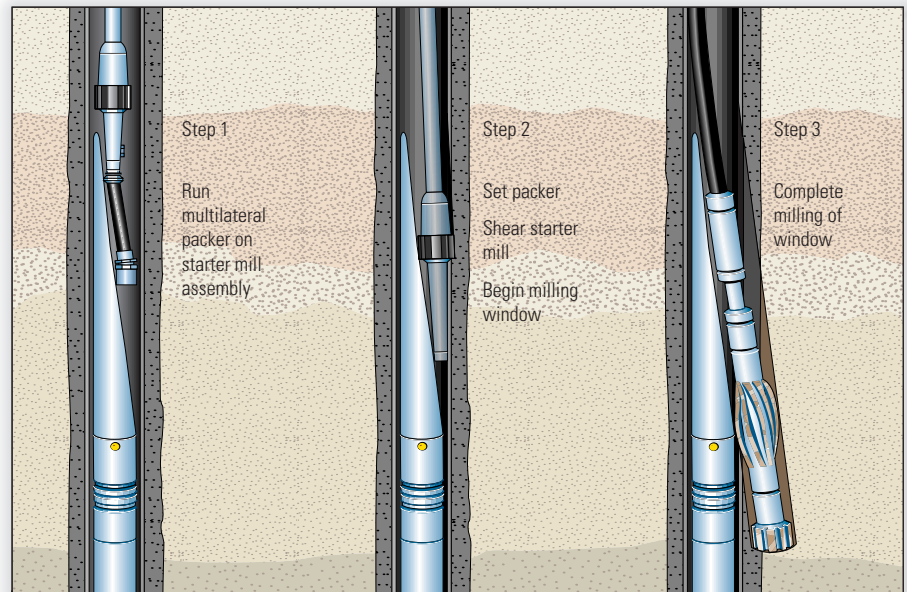

^ Window milling. Lateral openings are cut into the casing wall with whipstock and milling equipment. The whipstock packer is run and set on a mill assembly. The starter mill is then sheared off the top of the whipstock and a window is cut into the wall and formation to begin a lateral drainhole branch.

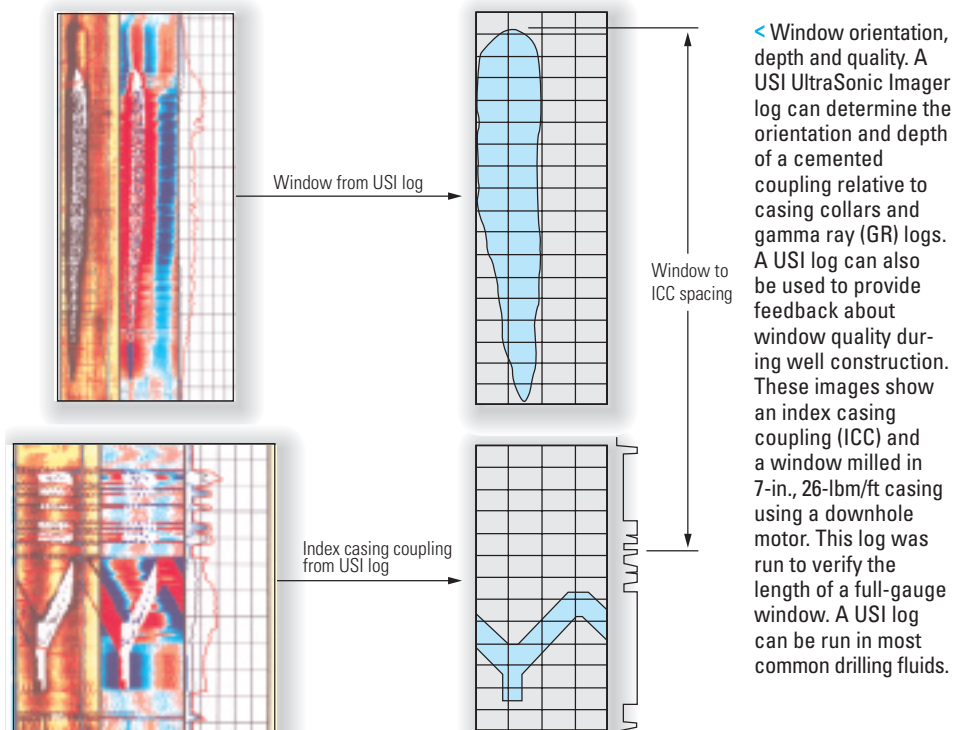

The most common completion performed in Level 2 and 3 wells is uncemented, predrilled or slotted liners and prepacked, but not gravel-packed screens. Anadrill uses a drop-off liner completion design in which the top of the liner in the lateral is immediately released outside the exit from the casing through a hydraulic sub. External casing packers are often used in the drop-off liner completion assembly to isolate zones, anchor the liner top and facilitate reentry access to the liner.

Another mid-tier approach to multilateral completion offers only individual hydraulic isolation of a lateral. In this case, laterals are drilled using whipstock sidetracking procedures and if any completion is performed in the lateral, it uses a drop-off liner. Conventional casing packers in the main casing with tubing between them—straddle packers—are used to isolate each of

the laterals hydraulically. Production from the laterals is controlled with sliding sleeves and other flow-control devices. This is an inexpensive and relatively straightforward multilateral completion method that was proven in the North Sea and is now being adapted for deepwater subsea wells.

The critical technology in these completions is operation of flow-control devices downhole. Schlumberger Camco intelligent well technology is now capable of activating and controlling these flow control devices remotely.

Level 4 multilateral wells have both the main bore and lateral cased and cemented at the junction, which provides a mechanically supported junction, but no hydraulic integrity. The lateral liner is, in fact, cemented to the main casing. The most common sidetracking procedure relies on whipstock-aided milling of casing windows, although premilled window-casing subs are also employed. There is no pressure seal at the junction interface of the lateral liner and the main casing, but the main bore and the laterals have fullbore access. This level of multilateral technology, although complex, high risk and still in development, has been successful in multilateral wells worldwide.

A Level 5 multilateral well is characterized by either the Level 3 or Level 4 lateral connection technique with addition of completion equipment to provide a pressure seal across the junction of the lateral liner and main casing. The main wellbore is fully cased and the junction is hydraulically isolated; cement is not acceptable as the hydraulic isolation. Reentry access to both the main bore and the laterals is available. Hydraulic isolation is achieved with the use of auxiliary packers, sleeves and other completion equipment in the main casing bore to straddle the lateral junction with production tubing.

Level 5 and 6 wells are distinguished from the mid- and lower tier levels by hydraulic isolation of the laterals as well as connectivity and accessibility characteristics. The most difficult aspects of multilateral technology are hydraulic isolation and integrity at high pressure, and most providers are still seeking ways of improving these.

Level 6 multilateral systems incorporate an integral pressure seal in the junction of the lateral liner and the main casing. A pressure-tight junction, achieved with an integral sealing feature or a monolithic formed or formable metal

design, is the goal and will be valuable in deep-water offshore and subsea installations.

Schlumberger first evaluated Level 6 multilateral technology in 1995 with a system developed by Anadrill, Camco and Integrated Drilling Systems. With multilateral technology development transferred from Anadrill to the Camco Advanced Technology Group, Schlumberger is evolving these techniques into newer systems rather than proceeding with this particular version. The company is continuing development of multilateral technology with a new Level 6 design.

Level 6S, a generally recognized Level 6 sub-level, uses a downhole splitter, or subsurface wellhead assembly, that divides the main bore into two smaller, equal-size lateral bores.

Positioning Multilaterals

Regardless of the design level or multilateral technology used, for lateral branches to achieve the desired contact with productive intervals, borehole direction must be an integral part of well plans. Determining these trajectories depends on reservoir properties, the rock stress

4. Ehlig-Economides CA, Mowat G and Corbett C: "Techniques for Multibranch Well Trajectory Design in the Context of a Three-Dimensional Reservoir Model," paper SPE 35505, presented at the European 3-D Reservoir Modeling Conference, Stavanger, Norway, April 16-17, 1996.

5. Roberts M, Kirkwood A and Bedford J: "Real-Time Geosteering in the Tern Field for Optimum Multilateral Well Placement," paper SPE 50663, presented at the 1998 SPE European Petroleum Conference, The Hague, The Netherlands, October 20-22, 1998.

Allen D, Dennis B, Edwards J, Franklin S, Livingston J, Kirkwood A, Lehtonen L, Lyons B, Prilliman J and Simms D: "Modeling Logs for Horizontal Well Planning and Evaluation," *Oilfield Review* 7, no. 4 (Winter 1995): 47-63.

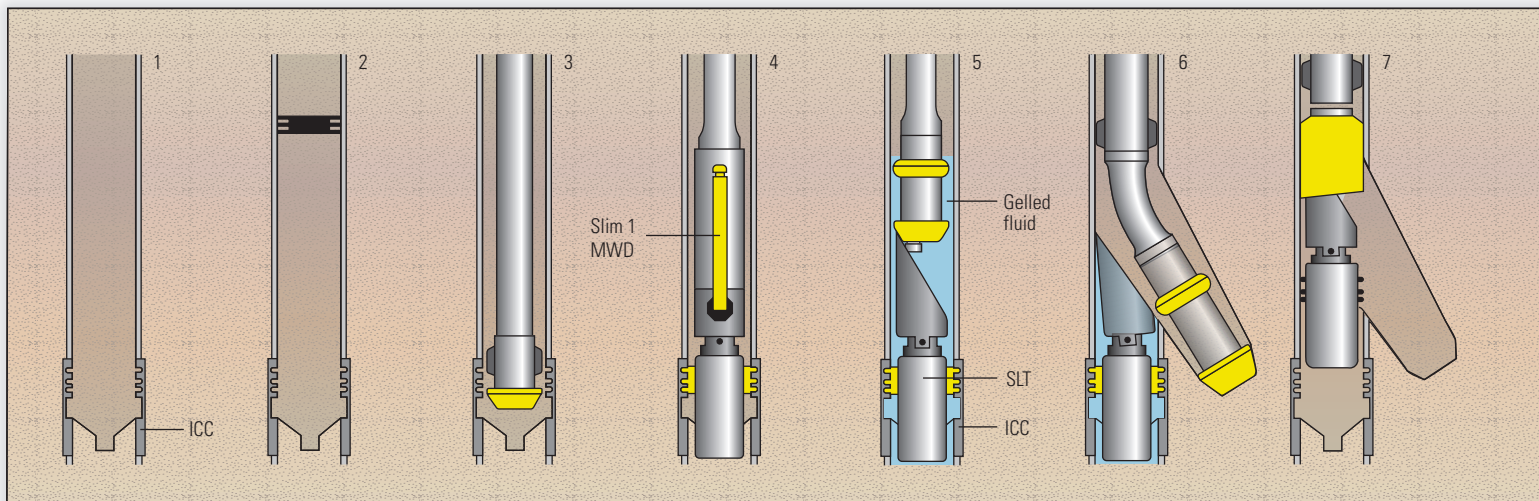

▲ The Level 2 multilateral process.

1. The main wellbore casing is run with index casing couplings (ICC) as integral components. The ICC, normally of standard coupling OD and pipe ID sizes, does not need to be oriented when run. It can be placed below, above or in angle-build sections.
2. The main bore casing is cemented using standard procedures and casing wiper plugs.
3. The lower branch is drilled, completed and isolated with a retrievable bridge plug.
4. The coupling orientation is determined from the USI log or by running a Selective Landing Tool (SLT) with Slim 1 MWD in the Universal Bottomhole Orienter (UBHO). During this trip the coupling can be cleaned with a special jetting tool and a gel pill may be spotted in the kickoff section to suspend debris.
5. The whipstock face is then properly aligned with the landing tool orientation key and run into the well. This assembly automatically aligns and latches in the appropriate coupling. The milling tool is then released from the whipstock.
6. A casing window and short pilot hole into the formation are cut with a special milling assembly powered by a downhole motor, in this case, an XP series PowerPak motor.

regime and the geometries of productive reservoir units. Laterals can be vertical, inclined or horizontal, as can the main wellbore, but because production from several laterals can be commingled in the main wellbore, it is possible to drill more drainholes in the reservoir than would be feasible with a conventional well.⁴

Trajectories for the main wellbore and laterals are determined using various information sources, including 3D surface and borehole seismic data, well logs and core analyses, formation and well testing, and other data like fluid properties and production histories. Pre-drill planning also ideally includes geological and petrophysical forward modeling with tools like INFORM Integrated Forward Modeling software to help identify risks and the value of logging-while-drilling (LWD) measurements. Such modeling provides initial petrophysical descriptions along proposed trajectories by using imported geological models (above). Thereafter, 2D and 3D LWD tool response functions are generally used to produce synthetic log datasets to complete forward models.⁵

Well path designs begin in the producing formation where the optimal lateral location is determined. From the farthest point in the laterals, the design proceeds to the main bore, then upward to the surface or seafloor wellhead. Both permeability and stress anisotropy are important

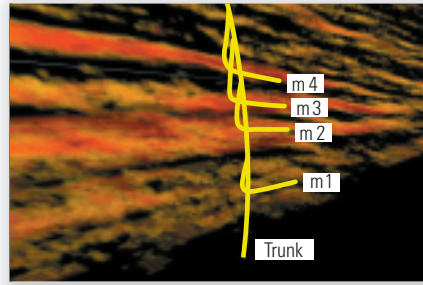

^ Subsurface models. Petrophysical descriptions along proposed well trajectories can be generated using imported geological models. Here four laterals (m 1, m 2, m 3 and m 4) branch from a main wellbore in a vertically stacked configuration.

considerations when selecting an optimal well path orientation in three dimensions. Production and perhaps drainage volume can be severely restricted by pressure gradients associated with converging flow in formations. Productivity can be enhanced if laterals are oriented to take advantage of permeability differences in producing zones or across an interval of different layers. For this reason, slanted and horizontal laterals are most productive when oriented perpendicular to natural fractures. When vertical permeability is much less than horizontal permeability, slanted laterals are best.

Closely spaced lateral branches increase the possibility of accelerated production and improved recovery efficiency in large reservoirs with thin zones or in thick zones underlain by water or overlain by gas. In reservoirs with structurally or stratigraphically isolated zones, multilateral wells are able to target the various layers with several laterals.

While multilateral wells are from the bottom up, risks involved in actually drilling drainholes develop from the top down. The best drilling and completion strategy is to construct laterals from the deepest branch up. This isolates risks at the lowest point and ensures that developing problems leave the wellbore above that point free of difficulty.

Drilling Multilaterals

The majority of multilateral wells drilled since 1953 have been Level 1 and 2 openhole completions in hard rock. Much of this drilling used relatively simple technologies, but as openhole completions with limited functionality give way to higher level multilaterals to meet the requirements of complicated reservoir and geological conditions, standard directional drilling is being replaced by increasingly complex technologies (previous page and below).

(continued on page 27)

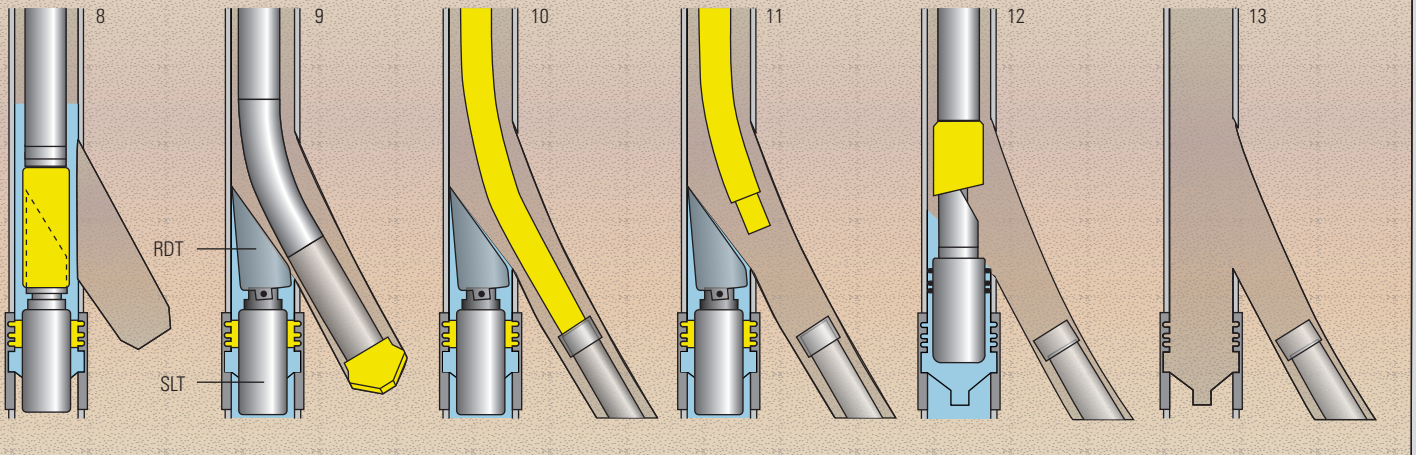

7. After a lateral is drilled to depth, it may be left openhole or a simple cemented or drop-off liner may be run. The landing tool is released and the entire assembly is retrieved from the well. The hole is cleaned out and the bridge plug is retrieved.
8. The process is changed for a cemented liner by replacing the full-size whipstock with a smaller diameter reentry deflection tool (RDT) that is run and latched into an ICC.

9. The bottomhole assembly (BHA) is run and a lateral branch is drilled.
10. A liner is run into the lateral and possibly cemented back into the main casing.
11. The liner running tool is released, the hole cleaned up by reverse circulating, and then the liner running tool is pulled out of the hole.

12. After the lateral is completed, the RDT is retrieved by releasing the selective landing tool (SLT), and both the RDT and SLT are pulled from the well.
13. The lower wellbore section is cleaned out, the isolating bridge plug is retrieved and the main bore is ready for completion.

Multilaterals in the Middle East

> Zakum field location and geology. Located northwest of Abu Dhabi in the Arabian Gulf, Zakum field produces from three stacked reservoirs with various layers in a large Cretaceous limestone. Three major producing reservoirs—I, II and III—are subdivided according to lithology.

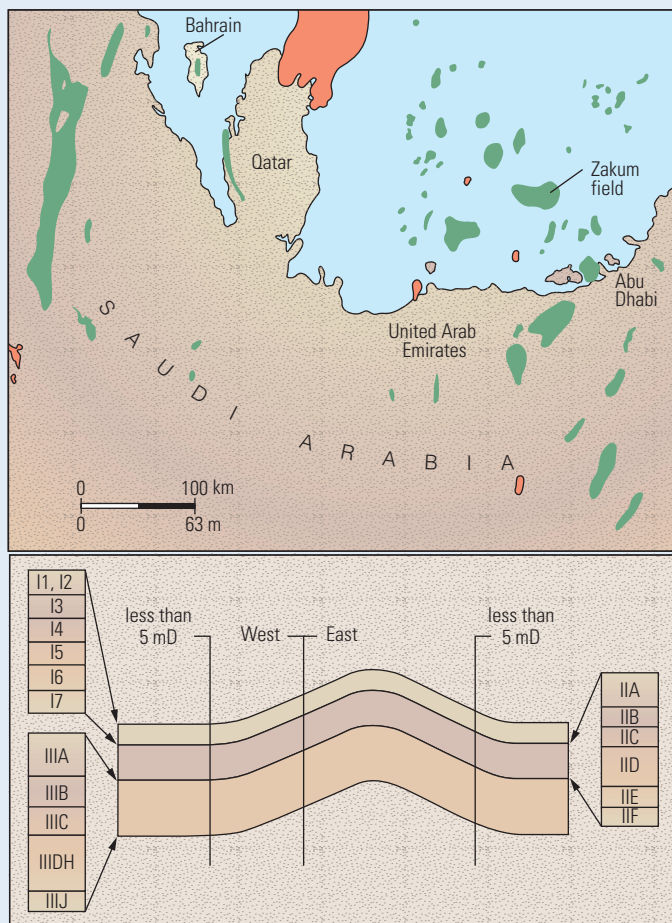

Since multilateral drilling began in the Middle East during the mid-1990s, it is estimated that more than 200 horizontal wells have been drilled in the region. In the United Arab Emirates, Zakum Field Development Co. (ZADCO) and its operating company Abu Dhabi Marine Operating Co. (ADMA-OPCO) are developing one of the largest Middle East oil fields. The experience of ZADCO with various aspects of multilateral horizontal drilling is typical of the state of this technology.

Zakum field, discovered in 1963, is situated offshore in the Arabian Gulf about 80 km [50 miles] northwest of Abu Dhabi. The producing formation is a large Cretaceous limestone with various layers in three main stacked reservoirs (above). Development began in 1977 with conventional drilling. Horizontal drilling was introduced in 1989 and extensive multilateral drilling commenced in 1994 as a

result of improvements in horizontal technology. The first multilateral well was completed in March 1995. Encouraged by a significant production increase, ZADCO decided to develop the stacked reservoirs using horizontal and multilateral drilling. To date, 39 dual-lateral and 45 multilateral wells have been drilled and completed, and more are planned.¹

During initial development, the complex of reservoirs was penetrated by a deviated wellbore and then by a single horizontal drainhole through most of the layers. These two techniques increased borehole exposure to the reservoir and allowed oil to be produced from the highest permeability layers, but oil in less permeable layers was left behind with subsequent substantial loss of reserves. Drilling separate drainholes for subzones provides a better opportunity for stimulation and enhanced production because each horizontal hole is connected directly to the main wellbore.

Drilling Multilaterals

Level 2 multilateral wells at Zakum field begin with a deviated section. After surface and intermediate casing are cemented, wells are deepened to 9-in. production casing or 7-in. liner depth just above lower reservoir targets with maximum inclination of 55° to facilitate wireline operations. Using a retrievable whipstock, a casing window is milled near the top reservoir and the upper drainhole is drilled using intermediate- and short-radius techniques. The whipstock is removed so that multiple openhole sidetracks and laterals can be drilled. The next horizontal hole is kicked off below the production casing string. Wellbore inclination is increased to horizontal and a lateral is drilled into the reservoir. A new deviated section is drilled from the last kickoff point and another lateral is drilled using the same procedures. Specialized or custom profiles, like stair-steps to maximize footage in certain intervals, can also be used (next page, top).

Curves are drilled with dogleg severity ranging from 6°/100 ft [31 m] to 10°/100 ft depending on reservoir requirements and whether medium- or short-radius techniques are used. Horizontal sections are typically 750 to 3000 ft [229 to 396 m] and the common hole size is 6 in. Position and direction in thin oil layers are achieved using measurements-while-drilling (MWD) and logging-while-drilling (LWD) to keep well trajectory within the required reservoir target interval.

Successful multilateral drilling depends on several factors, including zonal insulation, window milling, drilling dense barriers, early water breakthrough, low-departure targets, low-permeability zones, staying within targets, multiple holes from a single casing window and stimulation of multilateral openholes (next page, bottom left).²

1. Siddiqui TK, El-Khatib HM and Sultan AJ: "Utilization Of Horizontal Drainholes In Developing Multilayered Reservoir," paper SPE 29879, presented at the SPE Middle East Oil show, Bahrain, March 11-14, 1995.

2. El-Khatib H and Ismail G: "Multi-Lateral Horizontal Drilling Problems & Solutions Experienced Offshore Abu Dhabi," paper SPE 36252, presented at the 7th Abu Dhabi International Petroleum Conference and Exhibition, Abu Dhabi, UAE, October 13-16, 1996.

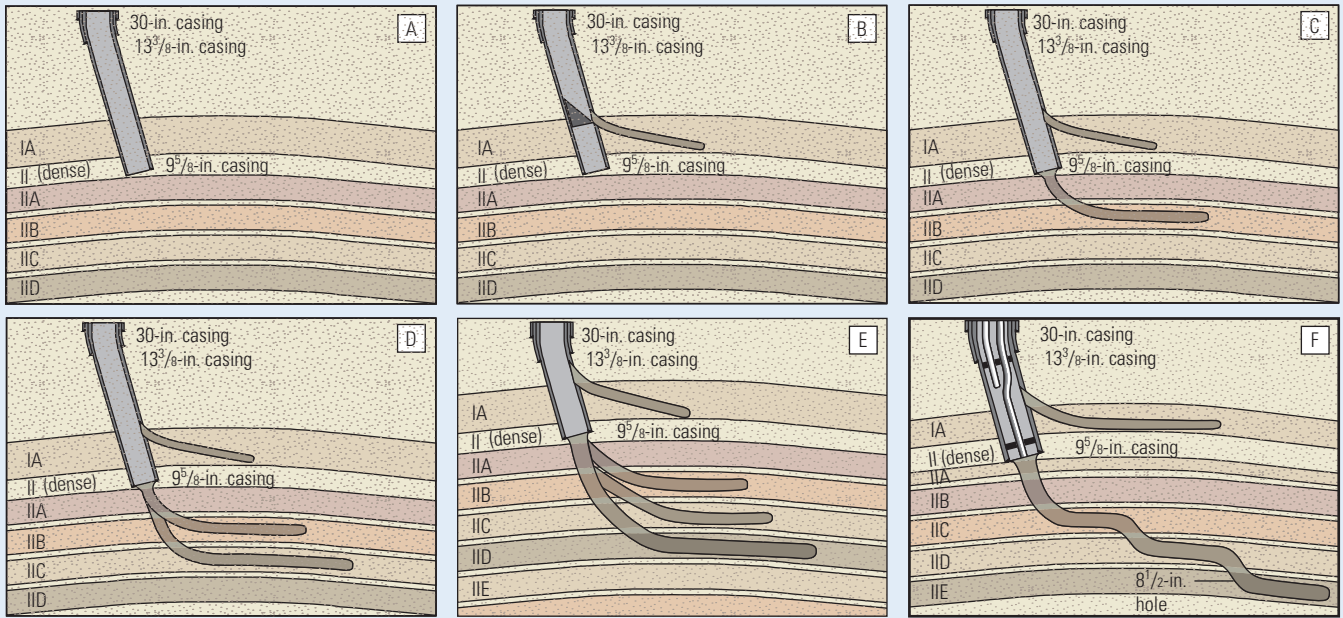

▲ **Drilling Zakum field multilateral wells.** The drilling sequence for a Level 2 Zakum field multilateral is as follows: A. Surface and intermediate casing are set and wells are deepened to production casing or liner depth just above the reservoir targets. Maximum inclination is 55° to facilitate wireline operations. B. A window is milled in the casing and the upper drainhole is drilled using intermediate- and short-radius techniques. C. The next horizontal hole is kicked off below the production casing string. D and E. New deviated sections are drilled from previous kickoff points so that more laterals can be drilled. F. Multilaterals with stair-step, traverse or other profiles can be drilled to minimize drilling in tight barriers, maximize horizontal footage in productive intervals and delay water breakthrough.

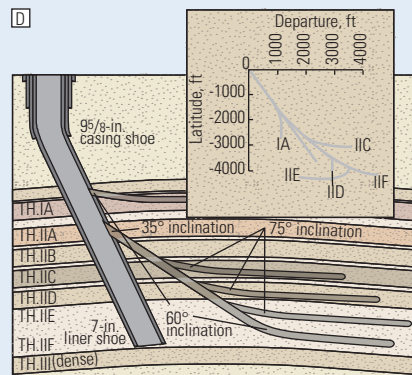
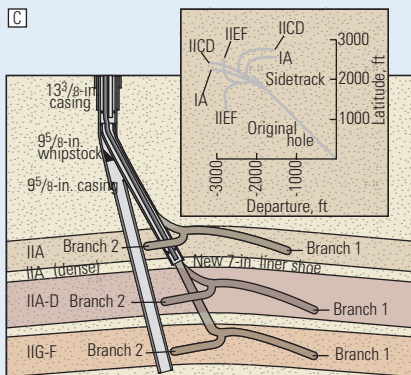
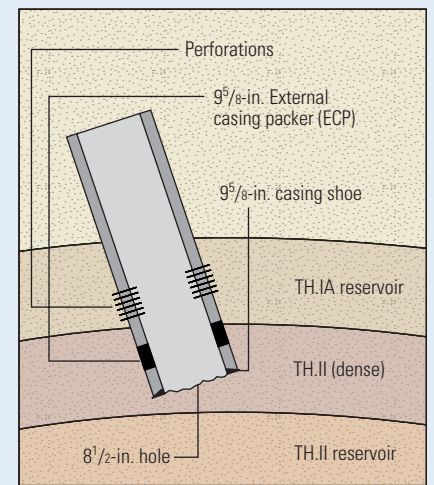
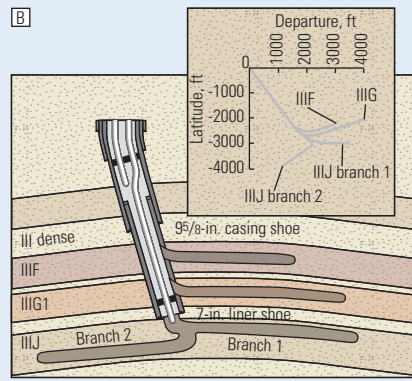
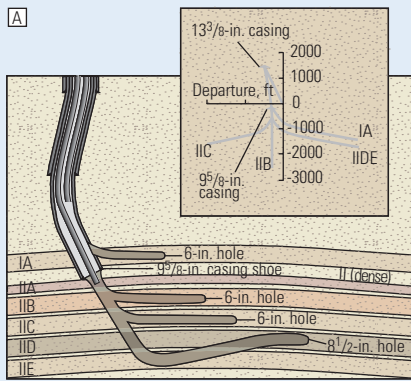

▲ **Zonal isolation.** In addition to optimizing cement slurries to improve primary cement jobs, external casing packers (ECP) are sometimes used to separate certain intervals.

Zonal isolation—The ability to achieve isolation is key to multilateral well success. Between upper laterals and lower drainholes, zonal isolation is extremely important due to pressure differential between the two reservoirs. Cement additives and operations were optimized to improve primary cement bond in addition to the use of external casing packers (ECP) on the production casing in some wells (above).

(continued on page 26)

Window milling—Using retrievable whipstocks and removal of these assemblies are critical to successful drilling of multilateral wells. More than 40 horizontal wells have been sidetracked with retrievable whipstocks. New single-trip whipstocks reduce the number of trips and the time necessary to exit the casing (right).

Drilling dense barriers—Because Zakum field porous layers are separated by tight reservoir rock, different techniques were adopted to minimize drilling in these dense, low-permeability barriers and maximize horizontal footage within specific reservoir zones to improve oil recovery. The technique of stair-step drilling through various reservoir layers is operationally difficult because of low angles of incidence when trying to cross barriers. Another technique, drilling separate drainholes for each reservoir zone, resulted in postdrilling problems associated with production monitoring and stimulation of individual drainholes.

Early water breakthrough—Multilateral wells are drilled to avoid or delay water breakthrough by selecting the horizontal section position and length within desired layers based on specific reservoir requirements.

Low-departure targets—Another challenge was drilling multilateral wells with targets less than 1000 ft [305 m] from the platform wellheads. Various options were considered to drill the deviated sections of these low-departure multilateral wells, but a hook-shaped profile was found to be operationally and economically the best. This well profile can be designed to have sufficient inclination to use previously successful medium-radius drilling. Several hook-shaped multilateral wells with four drainholes from the main bore were successfully drilled and completed.

Low-permeability zones—One benefit of a multilateral approach is the ability to exploit thin reservoirs. Developing stacked low-permeability limestone oil reservoirs is typically unattractive because of anticipated early water breakthrough in vertical or deviated wells. One of the field's reservoirs that held substantial oil in place was a 8 ft [2.5 m] thick zone with 6-mD permeability. Two branches were drilled in different directions to increase the drainage area and improve production. The number and geometry of the branches were dictated by reservoir characteristics.

Staying within targets—Another challenge for drilling multilateral wells is to correctly position and maintain horizontal sections within existing sweep patterns. Since branches drilled in opposing directions were found to be

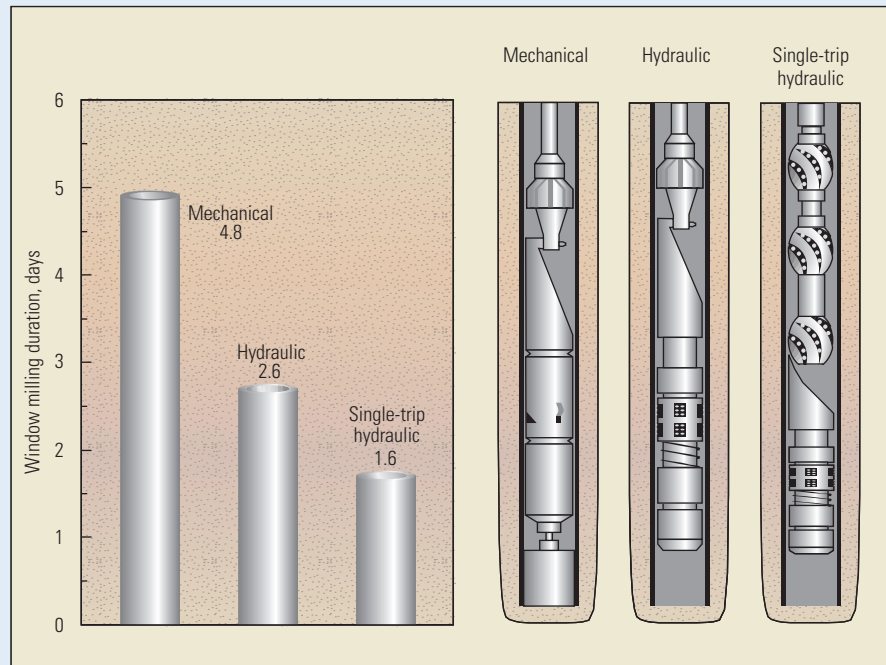

▲ Retrievable whipstock and anchor window milling performance.

optimum, severe left- and right-turning trajectories must be drilled to achieve the required reservoir exposure. A significant increase in production rates was observed in wells drilled in this manner.

Multiple holes from a single casing window—Several drainholes were successfully drilled from the same main borehole after exiting casing in reentry and new wells. This procedure can avoid the time and expense of multiple casing exits, but does limit the ability to monitor and stimulate laterals.

Stimulation of multilateral openholes—ZADCO uses openhole completions that commingled production from reservoirs I and II. Production from these two main reservoirs is kept separate using dual-tubing completion. Because of the inability of current through-tubing stimulation systems to access each drainhole selectively, common practice is to bullhead stimulation treatments—pump down the production tubing from surface. When possible coiled tubing was run through the production tubing to selectively treat individual openhole laterals in the main reservoirs.

Permeability variation in each productive layer requires that acid be diverted across all intervals where coiled tubing is unable to reach total depth. Techniques using diverting additives and procedures integrally combined with stimulation acid treatments are successful in increasing the productivity of some multilateral wells, but in many wells these diversion techniques cannot effectively stimulate the

desired number of laterals. Production logs are being used to further evaluate stimulation effectiveness as well as design and procedural modifications.

Future Multilaterals

Multilateral drilling in Zakum field provided an opportunity to improve recovery and manage field production more efficiently. Some 84 new and reentry Level 1 and Level 2 multilateral wells, from single and dual laterals up to seven laterals, were drilled and completed successfully in the last four years. Multilateral horizontal drilling brought new life to the field's thin, low-permeability reservoirs where development by deviated or vertical wells had not been effective. Horizontal wells with branches in opposing directions were the optimum solution. The future challenge is to conduct independent operations in each lateral and overcome zonal isolation difficulties.

After comparing drilling costs for different horizontal well types—medium, intermediate-radius and short-radius—ZADCO determined that short-radius drilling is more expensive than medium-radius wells, but short-radius wells are better in terms of production compared with vertical wells. Through rapid growth in short-radius drilling technology, the cost per foot of horizontal drilling was reduced by 30% after drilling 27 horizontal sections in ten wells. Lower costs, resulting from steerable drilling technology, encouraged ZADCO to continue drilling multilateral horizontal wells.

Short-radius wells, small-diameter wells and multiple radial slimholes are now being drilled not only in the Texas Austin Chalk region, but also in areas like the Middle East and Southeast Asia. In Alaska, USA, for instance, BP and Camco have drilled multilaterals with build angles of around 1.8°/ft, changing the well from vertical to horizontal in approximately 50 ft [15 m]. This steep build rate produces less formation damage, requires less time for drilling to target, uses less drilling fluid, and is generally more economical.

Small-diameter boreholes are drilled to reduce cost, and multiple slimhole horizontal reentries can be drilled from small-diameter wells to further increase reservoir exposure. Coiled tubing is also employed to drill multiple radials from the main bore. Coiled tubing drilling is frequently used to remove near-wellbore formation damage to increase reservoir flow potential, but in the Snorre field, Norway, for example, has also been used for drilling drainholes to replace perforations.

Multilateral reentry is not the sidetracking technique used for decades to salvage old wellbores that would otherwise have to be abandoned. Rather, it is an evolving technology for producing from and working over both the main bore and the laterals. Determining the right techniques for reentering multilateral wells to perform stimulation, acidizing, perforating or any other fluid pumping operation is a key problem confronting the oil industry today. As well configurations become more complex, the degree of difficulty increases.

Two major challenges are reentering a single branch at a specific depth and reentering multiple branches at the same depth. In addition, completion type, whether openhole or cased, the hole size and the vertical-to-lateral build rate represent primary factors involved in the selection of proper reentry techniques. The need to hydraulically isolate laterals impacts the choice of solution as well.

Reentry is a two-step operation: recognize the entry point and enter the lateral. One recognition method is accomplished by running a tool on coiled tubing that rotates to reentry depth. The tool has a bend on the end that provides a surface weight change indication when the bend enters a lateral opening. The Schlumberger coiled tubing VIPER system also has a bottom orientation sub that is used to locate and access laterals.

Mechanical methods are another way of achieving lateral entry. In a minimum of three runs, a whipstock diverting device is set; coiled tubing work is performed; and the diverter is retrieved. The tool carrying the diverter controls depth as it lands on a predefined tubing or casing profile nipple. The nipple provides tool orientation and allows the diverter to be located accurately at the lateral opening. This technique is used with completion equipment designed specifically for through-tubing reentry into laterals.

Reentry technology is evolving towards viable and reliable systems most likely based on a casing profile nipple or a tubing nipple and ported tubing sub aligned with the casing window, to which a bottomhole assembly will attach. An orientation locator coupled with upper and lower packer assemblies will find the orientation nipple and align the lateral access joint in the correct direction. A landing nipple plug will be used to isolate the lower packer or window joint for testing. An orientation device to accept a coiled tubing-conveyed diverter will facilitate access to the lateral opening for reentry.⁶

Wellbore Management

In production engineering and operation of multilateral wells, the key considerations are whether a well needs artificial lift and the degree to which imposed formation pressure drawdown is affected by frictional pressure drop inside the well. For example, short opposed laterals are preferable to a long, single horizontal well in one direction if drawdown is about the same as pressure drop in the wellbore. Conversely, if drawdown is several hundred psi, or more, a single horizontal leg may be adequate.

Selective wellbore control is provided by three basic completion configurations: individual production tubing strings tied back to surface, commingled production, and commingled production from individual branches that can be reentered or shut off by mechanical sliding sleeves or plugs. These options relate directly to reservoir management because the need for selective control increases as wellbores are opened to more areas of the reservoir. For example, laterals that drain multiple layers or different formations require selective management if pore pressures and fluid properties differ widely between zones. The degree of communication between the drainage areas of individual laterals may be the most important reservoir engineering issue in multilateral applications.

There are logistical and operational issues in completing certain well systems that may be dictated by obvious reservoir exploitation strategies and schemes. Currently, multilateral wells can be constructed with connectivity, isolation and access. Numerous completion choices are available. The following three configurations are common:

- Drain several stacked layers that may not be in communication
- Drain a single layer in which areal permeability anisotropy is critical
- Drain geologic compartments that may not be in communication.

Draining stacked layers favors a vertical main bore, but heterogeneous and compartmentalized reservoirs favor a single horizontal well, dual-opposing laterals, or multi-branched wells. Commingled production from stacked laterals is analogous to commingled production from two or more layers in a vertical well. The two main advantages of stacked laterals are that each lateral has greater productivity than a conventional vertical completion through the same layer, and that control of vertical inflow, or conformance, is facilitated because the productivity of each lateral is approximately proportional to its length. Vertical flow conformance avoids differential depletion under primary production and uneven water or gas breakthrough under secondary production.⁷

Future Multilateral Technology

Optimal multilateral connectivity will depend on the development of reliable junctions between the main bore and laterals as well as new completion strategies to connect more lateral wellbores with productive reservoir intervals. A first step will be the improvement of casing windows to facilitate efficient drilling and reentry of multiple lateral drainholes. Many in the industry believe that a technique must be developed to seal casing window connections. Considerable effort is being expended to perfect a reliable mechanical seal or new chemical sealants for TAML Level 6 wells to provide pressure integrity at the junction. Others maintain that the vast majority of multilaterals exit the main bore into the same reservoir, where the pressure differential at the junction is negligible. They advocate that, rather than pressure integrity, priority be given to developing fit-for-purpose junction integrity to increase production and the ability to manage laterals over the life of a well.

6. Turcich TA: "Pressure-Control Engineering," presented at the SPE Fourth European Coiled Tubing Roundtable, Aberdeen, Scotland, November 19-20, 1997.

7. Ehlig-Economides et al, reference 4.

Downhole construction of lateral junctions has associated problems such as generating debris and lack of cementing options. Surface construction, as in Level 6S wells, which can be done for new wells only, is debris-free, but limited to shallow wells.

There are also opposing opinions about construction of casing windows. Construction downhole favors milling standard casing by referencing inexpensive casing profile nipples or packers. Multiple nipples can be designed into casing strings, permitting operators to choose

sidetrack locations when they are ready and providing a reentry sleeve reference as well. Another possibility is to run a composite casing section with a profile nipple below it from which the drilling whipstock and lateral entry system sleeve can be spaced. Although there is no milling, casing strength is compromised (left).

Premilled windows or casing stock that has removable sleeves or is encased in drillable material are promoted by many to provide tensile strength without having to mill downhole. As with composites, the whipstock and lateral entry system sleeve are deployed through casing nipples. Generally, lateral casing is allowed to protrude into the main casing, where it is cemented in place and then milled or washed over to restore full main bore diameter. Both mechanical and pressure-tight tie-backs are being developed.⁸

Other technical issues need to be resolved as well, including the management and monitoring of production. Downhole control of flow with remotely operated chokes and other flow devices that independently optimize individual laterals and selectively shut-off zones to block water and gas—intelligent completions—will aid production management. Downhole permanent gauges for each lateral are also on the drawing board to monitor changes in pressure, temperature, flow rate, and water and gas cut. When connected to surface systems, these advances will permit additional surface measurement and eventually, the allocation of flow from each lateral. Selective reentry will permit servicing of these devices and sensors, and allow batch treating of each lateral.

Future multilateral wells will involve fewer trips into the well, incorporation of sealed lateral devices, and a full range of downhole controls and sensors to regulate flow, pressure and multiphase differentials. Downhole fluid separation and injection will be accomplished with surface control, and expensive rig interventions will be virtually eliminated by electrohydraulic control of downhole functions. This trend will reverse the risk-reward ratio offshore, where risks are high and reserves are large, in favor of multilaterals (left). Ultimately, multilateral well technology will be the basis for the intelligent completions that will one day yield remotely operated subterranean and subsea factories with oil and gas as the finished products. —DG, DEB, RR, MET

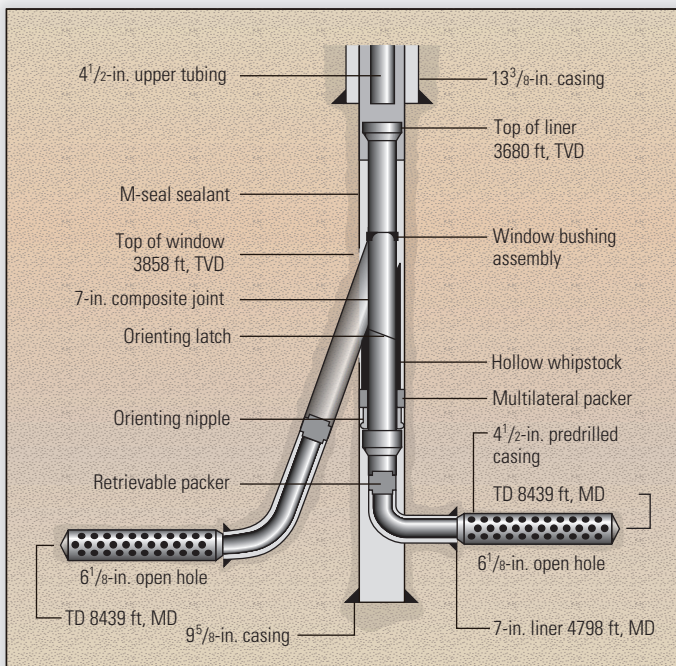

▲ Composite casing section with a nipple profile.

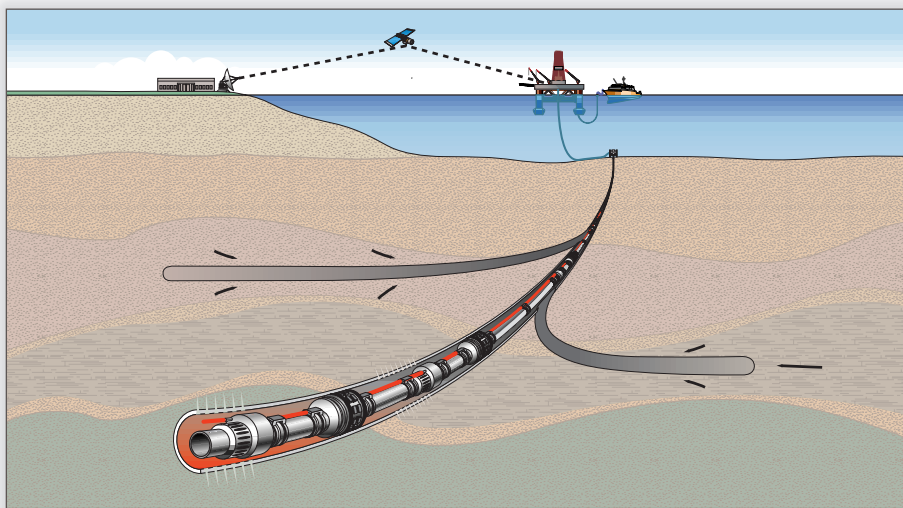

▲ Intelligent completions. Future multilateral completions may involve many processes, from formation drainage to downhole separation, inflow control, injection and reservoir monitoring.

8. Turcich, reference 6.